



ENZ

**4-Channel
Low-Current Monitor
LoCuM-4**

V 1.7

Documentation

www.beamline.net



In cooperation with FMB GmbH

Author: F. Enz, R. Franz

Manual Revision

revision no.	date	description
V 1.0	08.03.2004	- first public revision
V 1.1	07.07.2004	- for hardware serial number # 62340 and higher - implementation of 100pA range as standard - software controlled limits for automatic range switch - flashing BIAS LED on external BIAS
V.1.2	02.10.2004	- implementation LoCuM-4 –115V
V 1.3	17.03.2005	- « end of line » character changes from \r to \n for firmware 2.10 or later, integration window for limit range switch
V1.4	19.04.2009	adding new commands, individual range settings, upgrade utility
V1.5	29.09.2010	power parameters in specification added
V1.6	23.06.2011	band width frequency decreased
V1.7	28.09.2011	Chapter No Bias and splitted Bias

This device was developed in cooperation between ENZ Ingenieurbüro and FMB GmbH.
We are grateful to Dr. K. Holldack from BESSY GmbH.

Service address

ENZ Ingenieurbüro für Umweltelektronik & Automatisierung
Friedrich-Wöhler-Strasse 2
12489 Berlin
Germany

Phone: (++49) 030 – 63 92 52 80
Fax: (++49) 030 – 67 74 629

e-mail: info@beamline.net
Internet: www.beamline.net

1. Safety Instructions.....	5
2. Introduction.....	6
3. General Function	7
3.1. I/U Converter - Circuit Principle.....	9
3.1.1. Measuring Ranges 100 nA ... 1 mA.....	10
3.1.2. Measuring Ranges 100 pA ... 10 nA.....	11
3.2. Isolation Amplifier.....	11
3.3. BIAS Supply.....	12
3.4. Controller.....	12
3.5. Device Alternatives.....	13
3.5.1. Only External Bias for all 4 channels (option -B0).....	13
3.5.2. Splitted BIAS support (option -F2+2).....	13
4. Operating Instructions.....	15
4.1. Power-up.....	16
4.2. Ammeter	16
4.3. BIAS Supply.....	17
5. Using the RS-232 Interface (software control).....	19
5.1. RS-232 Interface Configuration.....	19
5.2. RS-232 Interface Commands.....	19
5.2.1. Command Format Used in this Manual.....	20
5.2.2. Command Summary.....	21
5.3. Upgrading Firmware (download mode).....	27
6. Examples for Interfacing	29
6.1. Using a VME crate to measure monitor signal levels.....	29
6.2. Using field bus modules to read raw data of position.....	29
6.3. Using a PC system.....	30
7. Specifications.....	31
7.1. General data.....	31
7.2. Current Measurement (Ammeter).....	31
7.3. BIAS Supply.....	32
7.4. Pin Assignment.....	33
7.4.1. Triax connector (current inputs).....	33
7.4.2. SUB-D15 connector (analogue OUT).....	33
7.4.3. SUB-HD15 connector X1 (Auxiliary).....	34

7.4.4. SUB-D9 connector (RS-232).....	34
7.4.5. SHV socket (BIAS-OUT).....	34
7.4.6. SHV socket (BIAS-IN).....	35

1. Safety Instructions

Please read this manual before using the LoCuM-4.

Metal parts arranged in the device, in particular the inside shielding casings of the I/U-converter and of the DC/DC-converters may be on a dangerous potential of up to 300V DC.

Switch off the device before opening it.

Disconnect the device from the measurement set-up and from the power supply system.



Only the manufacturer's service personnel is authorized to open the device and carry out maintenance, service, adjustment and repair works!

2. Introduction

The measurement of low-level currents that are biased in the range of hundreds of volts is a common problem in electron optics and as well in beamline monitoring. When steering and focusing a charge particle beam, it is often necessary to monitor some currents as the beam transmission is optimised by the adjustment of electrode voltages, e.g. to control the beam position.



For beam position monitoring it is necessary to measure four biased low currents in a system. The Low Current Monitor LoCuM-4 consists of four channel current-to-voltage converters, a BIAS supply, an optically isolated amplifier and an interface to a host system.



All components are implemented in a 19"/ 2 units rack mounting case. The front side inputs are for pieces of Triax inputs. All standard outputs and control signals are located on the rear as Sub-D connectors. The bias monitor output and the external BIAS supply can connect with SHV connectors.

3. General Function

The four-channel Low Current Monitor LoCuM-4 consists of several components:

- Four I-U-converters
- Four channel isolation amplifiers
- BIAS supply
- Controller
- Power supply

The figure below shows a block diagram of the LoCuM-4 device:

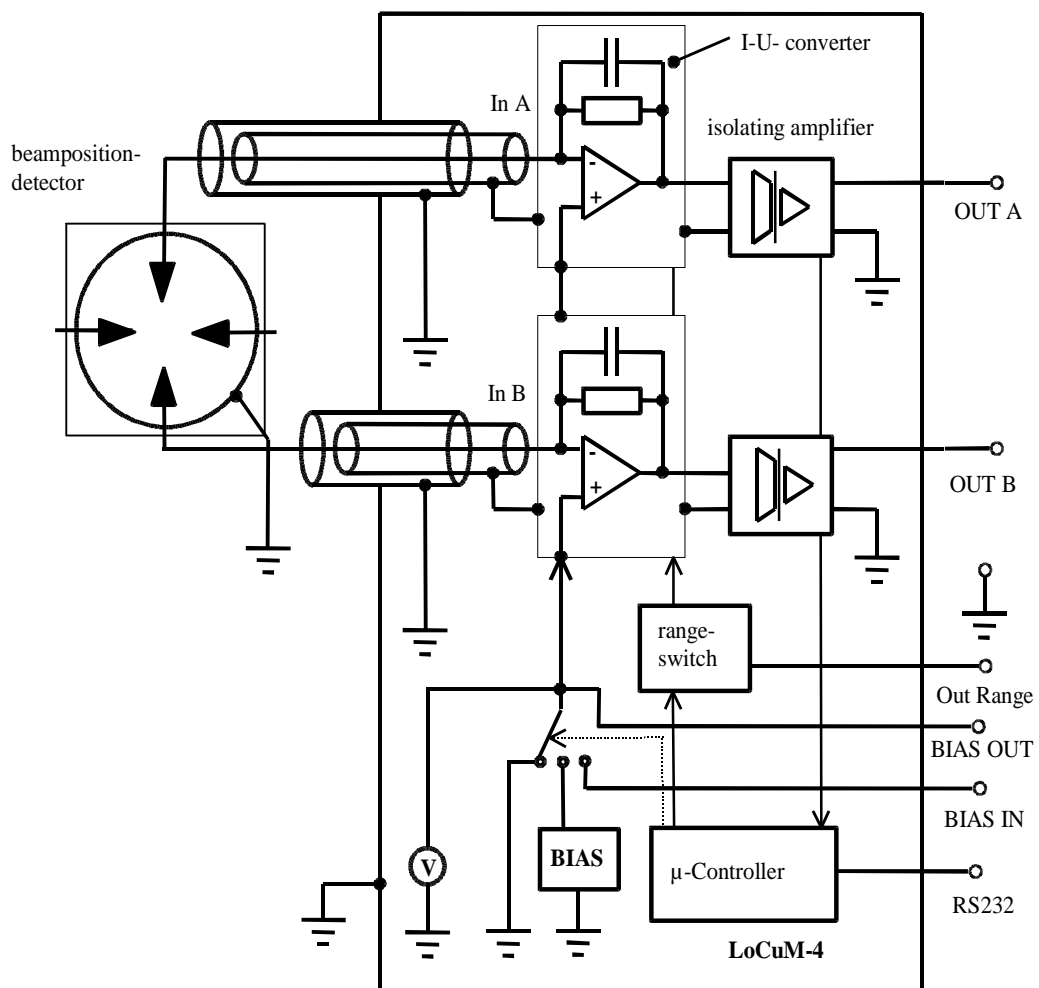

Block schematic of the position monitor (only two of the four channels are shown)

The currents generated in the detectors (e.g. beam position detector) flow via double-shielded measuring cables into the four I/U-converters where the currents are converted into proportional voltages.

The LO(low) potential circuit (inner shield) is either closed directly via the ground potential or via the add-on BIAS voltage source.

The outer shield is always connected to the ground.

The current-proportional voltages are connected to four isolating amplifiers to realize a galvanic isolation between the current inputs and the outputs of the LoCuM-4. Thus it is guaranteed that no dangerous Bias voltage will ever be present at the outputs.

The I-U-converters can operate in several ranges of input currents.

To control the input range selection, the implemented controller measures the actual input levels on all four channels and automatically switches to the correct range. It is also possible to switch the range manually.

The correct shielding of all input components is very important.

3.1. I/U Converter - Circuit Principle

With large currents, ammeters operate as Shunt-Ammeters. For very small currents, such as in this case, the ammeter operates as a Feedback Ammeter. The following schematic shows an I-U-Feedback Ammeter for two different input ranges and a post amplifier.

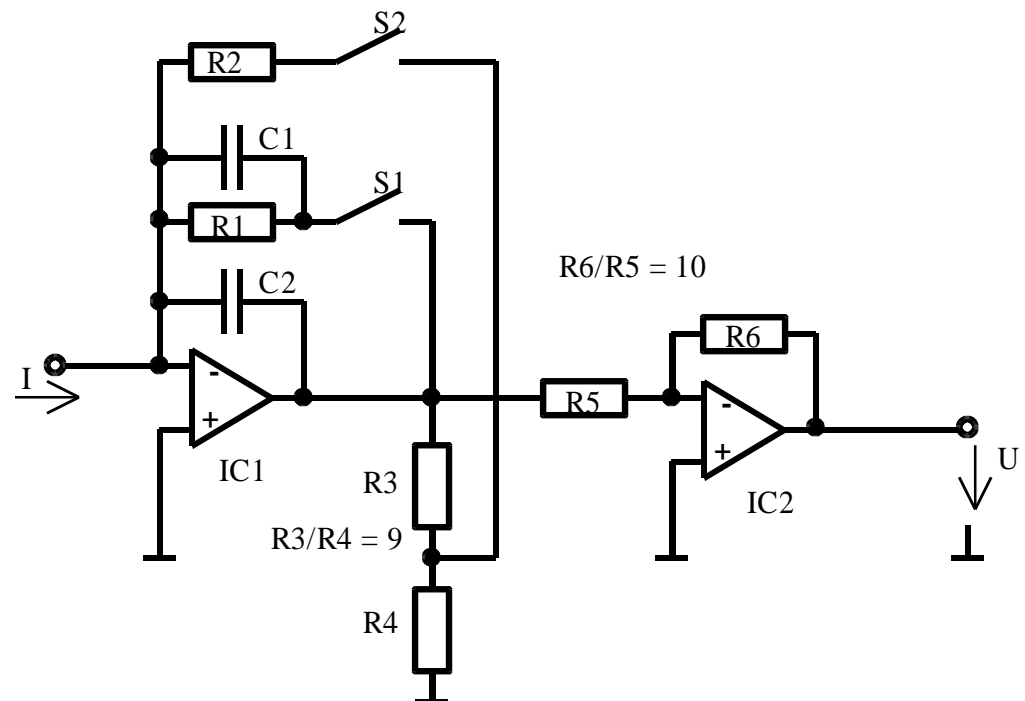

Input unit (simplified illustration)

All components, especially the operational amplifiers used for IC₁, IC₂ and the capacitors C₁ and C₂, are deemed ideal with a view to the following considerations.

3.1.1. Measuring Ranges 100 nA ... 1 mA

(Switch S_1 closed, S_2 is open).

a) Static consideration (direct current):

Input current I flows through the feedback resistor R_1 . The low offset current of amplifier IC_1 changes the current by a negative amount. The amplifier output voltage is calculated as follows:

$$U_{outIC1} = -I * R_1$$

A negative voltage amplification is produced on IC_2 via R_5 and R_6 :

$$U = I \cdot R_1 \cdot \frac{R_6}{R_5}$$

b) Dynamic consideration (alternating current):

Together with resistance R_1 and the capacitors C_1 and C_2 , IC_1 generates a low-pass filter of the first degree. The signal is subject to attenuation with increasing frequency.

The threshold frequency (3dB attenuation) is the following:

$$f_g \approx \frac{1}{R_1 \cdot 2 \cdot p \cdot (C_1 + C_2)}$$

3.1.2. Measuring Ranges 100 pA ... 10 nA

(Switch S_2 closed, S_1 is open).

a) Static consideration (direct current):

Current I flowing via resistance R_2 causes a voltage drop $-U_1$.

A voltage amplification is obtained via multiplier (voltage divider) R_3/R_4 . A negative voltage amplification is produced on IC_2 via R_5 and R_6 . Since the voltage divider R_3/R_4 has a lower impedance than the feedback resistance R_2 , an unloaded voltage divider may be assumed:

$$U = I \cdot R_2 \cdot \left(1 + \frac{R_3}{R_4}\right) \cdot \frac{R_6}{R_5}$$

b) Dynamic consideration (alternating current):

Together with resistance R_1 and the voltage dividers R_3/R_4 and the capacitor C_2 , IC_1 generates a low-pass filter of the first degree. The voltage divider leads to the effect that the reverse feedback resistance R_2 has a greater influence on the time constant of the low-pass filter by the

factor of $\left(1 + \frac{R_3}{R_4}\right)$.

The signal is subject to attenuation with increasing frequency.

The threshold frequency (3dB attenuation) is the following:

$$f_g \approx \frac{1}{R_2 \cdot \left(1 + \frac{R_3}{R_4}\right) \cdot 2 \cdot p \cdot C_2}$$

3.2. Isolation Amplifier

The four isolation amplifiers realize the galvanic isolation between BIAS-sourced current inputs and low-level outputs. Both sides of the iso-amplifiers are supplied from different power supplies. The gain of these amplifiers is 1:1.

3.3. BIAS Supply

The LoCuM-4 allows supplying all current inputs with one BIAS voltage. An internal source generates 0...300 Volt DC. The internal BIAS module generates a maximum current of 10 mA. For higher currents up to 100 mA it is possible to connect the LoCuM to an external High-Voltage module. For this application an SHV connector is provided on the rear panel.

The BIAS voltage can be controlled by a potentiometer in the range of 0 Volt to 300 Volt.

It is possible to change the polarity of the internal BIAS.

A manual main flip switch switches the BIAS "ON" or "OFF". This function cannot be remotely controlled by the remote controller.

On the rear panel there is a high-density Sub-D-15 connector to connect a BIAS interlock. If a 5...10 V DC (10mA) signal is connected, the BIAS will be switched off immediately. This is useful, if the vacuum is lost. In some cases a high BIAS on position detectors with a lost vacuum can generate problems.

3.4. Controller

A flash controller manages the internal switch function and allows manipulating the LoCuM in remote mode. The controller measures the maximum level in all four channels and generates an automatic range signal. The controller will also handle the front LEDs and switches. The micro-controller controls some of the BIAS switchable functions.

When the controller generates the current range signal, it also builds the analogue range signal using a DA converter.

A serial RS232 interface allows monitoring the status of the LuCuM-4 from a host system. In the remote mode most switch functions can be manipulated via a serial interface.

An automatic offset correction and remote offset manipulation is in preparation and will be available soon.

3.5. Device Alternatives

For special requirements there exist 2 more variants of Locum-4 device.

3.5.1. Only External Bias for all 4 channels (option -B0)

The internal BIAS Source is not implemented. So there are no operational BIAS controls. Only a switch for connecting the inputs of the ammeter to an external sourced potential still exists.

With the BIAS switch you can either switch the external BIAS (position Ext. Bias) or the the main ground (position 0V) to the ammeter.

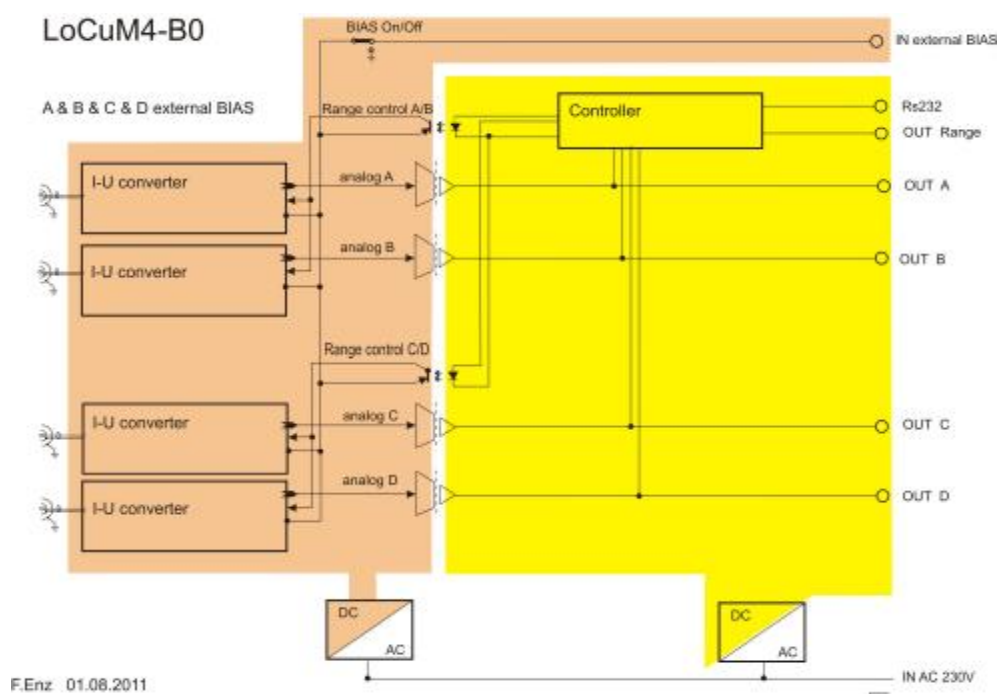

The interlock function is not available. If you need that, you have to use the interlock of your external BIAS source!

Take care, that the maximum external voltage is lower than 300 VDC

3.5.2. Splitted BIAS support (option -F2+2)

Another option is the splitted BIAS support. For the channels A and B you can supply an external sourced BIAS potential. This part is equal to option “-B0”.

The ammeters for the channels C and D have the main ground potential. Both groups are galvanically isolated.

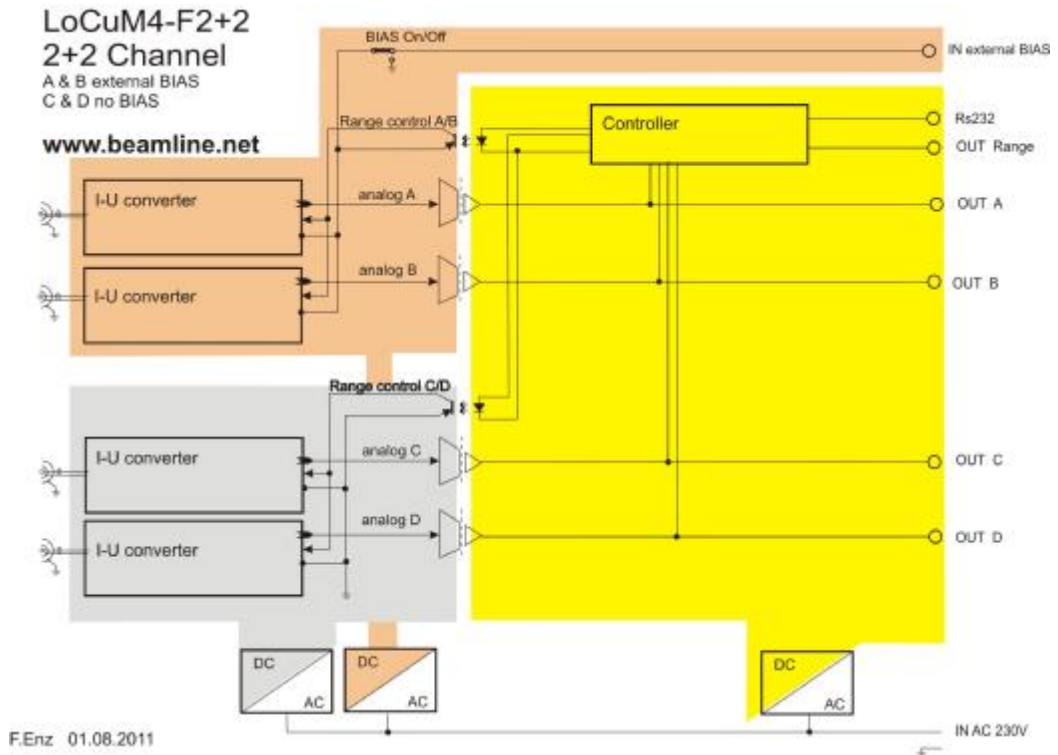

The interlock function is not available. If you need that, you have to use the interlock of your external BIAS source!

Take care, that the maximum external voltage is lower than 300 VDC



4. Operating Instructions

Before switching the LoCuM-4 on, please note the following:



Check the correct power supply. The standard devices need a 230 Volt AC power connection. Optional a 115 Volt AC version is available. Look at the rear power connector. It is NOT possible to switch between 230VAC and 115 VAC !!

Ensure that the measurement set-up is safely grounded, that the measuring device itself is not damaged and that there are no damages on the measuring lines or on any other devices that are part of the measurement set-up.



Switch the flip-switch BIAS to the position “OFF”, turn the selector-switch of the BIAS voltage source to the position “0V” and turn the setting potentiometer of the BIAS voltage source completely to the left (position 0.0).

The device’s main-switch is located on the rear panel of the device.

After having switched on the device, the internal controller starts a self-test. During this time the Range LED will flicker. A voltage value (0V) will appear on the LCD-display (BIAS).



Before switching the LoCuM-4 off, make sure that the BIAS voltage is deactivated.

4.1. Power-up

After switching on the device, it takes approximately 3 seconds to initialise the device. During this time the Range LEDs light up from bottom to top and the „1mA“ RANGE and the BIAS voltage source „0 volt“ are active, independent of the position of the front switches. The BIAS voltage value will appear on the LCD-BIAS display. After initialisation the switched RANGE LED of the measuring range display will light up and the BIAS voltage is connected to the selected source.

The measuring range (0 –5 volt) is available as an analogue voltage on the rear panel of the device via a SUB-D 15 plug.

When turning the measuring range switch (Range) completely to the right („AUTOMATIC“), the red LED lights up and the four measuring amplifiers will automatically be switched to the correct measuring range.



Before switching on, make sure to deactivate the BIAS voltage.

4.2. Ammeter

The ammeter consists of four separate channels measuring the input currents with I-U-converters to a common potential and converting them into direct current values between 0 and $\pm 10V$.

On the left side of the front panel there are the four Triax input sockets of the measuring channels (A...D). Next to them at the right hand side there is a measuring range selector with LEDs and a switch.

When turning the measuring range switch (Range) completely to the right („Auto“), the red LED will light up and the four measuring amplifiers will automatically be switched to the correct measuring range.

By turning the switch to the right, the measuring range will be selected manually. The current measuring range is displayed by the corresponding green LED lighting up.

The measurement values of the four input channels and the measuring range are available as analogue voltages on the rear side of the device via a male SUB-D 15 plug.

It is strongly recommended that only a specially adapted type of triax-cable is used for current input to get the best measuring performance.

Please use only noise-reduced triax-cables manufactured by ENZ Ingenieurbüro.

see www.beamline.net

4.3. BIAS Supply

The operating elements for the BIAS supply can be found on the right side on the front panel of the device:

On the left side of the LCD-display there is a switch to select the polarity, for the grounding and for using an external BIAS source.



These functions of the switch can also be controlled by remote control. On the right-hand side of LCD-display the potentiometer to adjust the BIAS voltage is located.

The Main ON/OFF switch for the BIAS voltage and a red LED are located below the display. These functions of this switch cannot be controlled by remote control.

If the Main BIAS switch is “ON” and the BIAS interlock is ok, the red LED will show you a BIAS operation mode indicating that the internal or an external source is working.

Turn the potentiometer completely to the left (position 0.0) before actuating the selector switch for the selection of the polarity or grounding or external source.

The set BIAS voltage can be read at the SHV monitor output socket (on the rear panel of the device).

The BIAS supply permits to increase the inputs of the ammeter to potentials of up to 300V. With a rotary-type switch you can select the polarity of the internal BIAS voltage or connect the output to the ground or use an external BIAS source (up to 300 V DC and max 100mA). An SHV output socket located on the rear panel of the LoCuM provides a monitoring output of the BIAS voltage. The BIAS voltage is connected to the input levels by means of a joystick selector. The voltage is also applied on the SHV socket "BIAS" even if the switch "BIAS" is "OFF".

With the flip-switch (BIAS) you can either switch the set BIAS voltage (position: ON) or the main ground "PE" to the ammeter (position: OFF).

If an external BIAS is used (set selecting switch to "EXT") and the Main BIAS switch is "ON" and the BIAS interlock is ok the red LED is flashing.

5. Using the RS-232 Interface (software control)

On the rear panel of LoCuM-4 there is a Sub-D-9 connector to realise a RS-232 connection to a host system, for example to a PC or VME system. This remote interface allows reading the LoCuM system status and control some functions. It is not possible (at present) to read the current values.

The device state changes to remote control by receiving a known command. In this case all switches (except main BIAS ON) on the front panel are disabled. As an indicator the automatic range LED switches off for a short pulse if the range selector operates in automatic mode; or this LED switches on for a short pulse, if the device operates in non-automatic range control.

There is no local mode switch. However, a special switching sequence of the measuring range switch returns the device to local control.

5.1. RS-232 Interface Configuration

You connect the device to the RS-232 interface using the 9-pin (DB-9) serial connector on the rear panel. The current meter is configured as a DTE (*Data Terminal Equipment*) device. For communication over the RS-232 interface, the device uses no handshake lines. The configuration of the RS-232 interface is fixed with the following settings:

- Baud Rate: *9600 baud*
- Parity and Data Bits: *None / 8 data bits*
- Number of Start Bits: *1 bit*
- Number of Stop Bits: *1 bit*

5.2. RS-232 Interface Commands

The interface commands corresponds to SCPI (*Standard Commands for Programmable Instruments*), ASCII-based instrument command language and some common IEEE-488.2 standard commands.

SCPI commands are based on a hierarchical structure and always begin with a colon (:). Common IEEE-488.2 commands always begin with an asterisk (*) and they are four to five characters in length.

In contrast to a GPIB bus every command has a start delimiter and a device address. Multiple commands are not allowed.

5.2.1. Command Format Used in this Manual

The format of all commands is specified in the following way:

start-delimiter address command[parameter] end-of-line

For example: `$01*IDN?<lf>`

element	value	length
start delimiter	„\$“ ASCII 24 hex	1 Byte
address	„01“ to „FF“ 2 character ASCII text	2 Byte, fixed in the device, not changeable
end of line	„\n“ ASCII 0A hex (new line)	1 Byte
command	see below	

The command syntax shows commands as upper-case letters. The upper-case letters indicate the abbreviated spelling for the command.

Send only this abbreviated form. Commands are case sensitive.

Braces ({ }) enclose the parameter choices for a given command string.

The braces are not sent with the command string.

A *vertical bar (|)* separates multiple parameter choices for a given command string.

Triangle brackets (< >) indicate that you must specify a value for the enclosed parameter.

Some parameters are enclosed in *square brackets ([])*. The brackets indicate that the parameter is optional. The brackets are not sent with the command string.

If you send two commands without reading the response (if there is one) from the first, the second command is ignored. To avoid this, do not send a command without reading the response. The response time is typically 100ms.

A command string sent to the device *must* terminate with a *<line feed>* character. **With firmware version prior to “2.10” command strings terminate with a *<new line>* (ASCII hex “0D”) character.**

You must insert a *blank space* to separate a parameter from a command keyword.

5.2.2. Command Summary

This section summarizes all commands available to program the LoCuM-4 device. Refer to the following sections in this chapter for more complete details on each command. The address „01“ is used by default below.

- :CONF? Querying configuration
- :CONF Configure device
- :SYST System-related commands
- *IDN? Querying identification
- *RST Reset device to power-on configuration.
- *CLS Querying status and clear status
- :MEAS Querying a rectified channel peak value

5.2.2.1. Querying Configuration: CONF?

Command	\$01:CONF?<lf>
Response	"S1_value1,S2_value2,HV_value3,Ext_value4, Bias±_value5,Auto_value 6,"<lf>
value1	indicates the measuring range: "100pA", "1nA", "10nA", "100nA", "1µA", "10µA", "100µA", "1mA", "Auto", "Err", "Single" ⁴⁾
value 2	indicates the BIAS voltage source: "Minus", "Plus", "Ext", "Err", "0Volt"
value 3 to value 6	indicates the ON/OFF state: "ON", "OFF"

if value1 = "Single" you have to read the current channel setting with "CONF:CURR?"

5.2.2.2. Querying Configuration: CONF:CURR? ⁴⁾

Command	<code>\$01:CONF:CURR?<If></code>
Response	<code>"Ch{A/a}_value,Ch{B/b}_value,Ch{C/c}_value,Ch{D/d}_value,"<lf></code>
value	indicates the measuring range for each channel: "100pA", "1nA", "10nA", "100nA", "1µA", "10µA", "100µA", "1mA", "Err",

If the channel letter Ch? is in upper case, this channel operates in "automatic range mode", in lower case there is a individual range setting, e.g. ChA_100pA means: the range for channel A is 100 pA and automatic mode for this channel is selected, Cha_100pA means: range is 100 pA set by command.

5.2.2.3. Configure Measuring Range: CONF:CURR

If you set one single channel to "range", there is no signal output (0 VDC) on SUB-D15 connector (analogue OUT) Pin 7 (out range). All individual range settings remain valid while device is powered. You can switch from individual settings to settings for all four channels without the lost of the individual settings.

Command	<code>\$01:CONF:CURR:<chan> { <range> MIN MAX DEF }<lf></code>
Response	none
chan	"DC" and "DC0" set all four channels to <range>, "DCA" set channel A to <range>, ⁴⁾ "DCB" set channel B to <range>, ⁴⁾ "DCC" set channel C to <range>, ⁴⁾ "DCD" set channel D to <range>. ⁴⁾
range	"1E-03" to " 1E-10" in unit Ampere, from 1 mA (1E-03) to 100 pA (1E-10),
MIN	selects the lowest range; MAX selects the highest range; DEF selects auto ranging

5.2.2.4. Configure BIAS Voltage Source: CONF:BIAS

Command	<code>\$01:CONF:BIAS:SOURCE { PLUS MINUS EXT DEF }<lf></code>
Response	none
EXT	selects the external BIAS source
DEF	selects 0 volt source (main ground)

5.2.2.5. System: SYST:ERR?

Command	<code>\$01:SYST:ERR?<lf></code>
Response	"No_Error"<lf>
	There is no error status at the moment!

5.2.2.6. System: SYST:LOC

Command	<code>\$01:SYST:LOC<lf></code>
Response	none
	With this command you cancel the remote control and go back to local control.

5.2.2.7. System: SYST:VERS?

Command	<code>\$01:SYST:VERS?<lf></code>
Response	"SCPI_ENZ_x.xx"<lf>

5.2.2.8. System: SYST:COMP? ¹⁾

Command	<code>\$01:SYST:COMP?<lf></code>
Response	"ChD 9800,0800"<lf>"ChC 9800,0800"<lf>"ChB 9800,0800"<lf>"ChA 9800,0800"<lf>
	channel limit values for each channel in millivolts beginning with upper limit followed by lower limit

5.2.2.9.System: SYST:COMP ¹⁾

Command	<code>\$01:SYST:COMP:{HI LO}:{CHA CHB CHC CHD ALL} value<lf></code>
Response	<code>"Comp_{Err HI_ LO_}{CHA CHB CHC CHD ALL}"<lf></code>
value	value for upper (HI) or lower (LO) limit in millivolts in range from 1 to 9999 mV for automatic measurement range mode
HI	upper limit
LO	lower limit
ALL	set all four channels to the same value

Recommendation for setting the limit values:

- lower limit ≥ 500 mV
- upper limit ≤ 9900 mV
- upper limit $\geq (\text{lower limit} * 10) + 300$ mV

By default the lower limit is set to 800 mV and the upper limit to 9800 mV.

This parameters are relevant only in automatic mode.

In this case the device will switch to the next higher range if ONE of the channels is above the upper limit value. But only if ALL channels fall below its lower limit value the measuring range is decreased.

5.2.2.10.SYST :ADR ¹⁾

Command	<code>\$01:SYST:ADR value<lf></code>
Response	<code>{"New Address value" "Err"}<lf></code>
	set a new device address in the range from "01" to "FF" in hexadecimal notation either with prefix "0x" or without any prefix. The new address is stored in eeprom and is valid with the next command. Address "0" is not allowed!
value	in the range from "01" to "FF"

By default the address is set to «01».

5.2.2.11.SYST :INTL ³⁾

Command	<i>\$01:SYST:INTL value<lf></i>
Response	{ <i>"New INTL: value" "Err"</i> } <i><lf></i>
	set a new integration window length in the range from "4", "8", "16", "32" or "64" in decimal notation. The new value is stored in eeprom and is valid immediately! "Value" is the count of summation values for the calculation of one rectified peak value. By default "INTL" value is "16" .
value	only "4" or "8" or "16" or "32" or "64"

5.2.2.12.SYST :INTL? ³⁾

Command	<i>\$01:SYST:INTL?<lf></i>
Response	<i>"MVSL: value"<lf></i>
	"Value" is the count of summation values for the calculation of one rectified peak value.

5.2.2.13.Identification: *IDN?

Command	<i>\$01*IDN?<lf></i>
Response	<i>"LoCuM4,Version x.xx,Address y,#zzzzz\ "<lf></i>
	Read the identification string; version und address in decimal notation; the serial number after „#“

5.2.2.14.Reset Device: *RST

Command	<i>\$01*RST<lf></i>
Response	<i>"Reset"<lf></i>
	Reset the device to its power-on configuration (Measuring Range: 1mA; BIAS Voltage Source: 0 volt). Useful only in remote control!

5.2.2.15. Querying Status: *CLS

Command	\$01*CLS<lf>
Response	P3_P4_P0:<lf>XXYYZZ
	Device first responses with a string terminated with the <new line> character, followed by 6 ASCII characters (in the range from 30 hex to 3F hex)
XX	Low-Level value for front panel switches
YY	Low-Level value for measuring range
ZZ	Low-Level value for automatic ranging

The first byte is the high nibble of the low-level byte value. Each nibble is shifted with 30 hex to printable characters. So you have to eliminate this offset first.

Front panel switches:

bit7	bit6	bit5	bit4	bit3	bit2	bit1	bit0
External Relay	Minus Polarity Relay	Bias ON Relay	HV LED	Auto LED	MSB LED	LED	LSB LED

Measuring Range:

bit7	bit6	bit5	bit4	bit3	bit2	bit1	bit0
1mA	100 µA	10 µA	1 µA	100nA	10 nA	1 nA	100pA

Automatic Ranging: ²⁾

bit7	bit6	bit5	bit4	bit3	bit2	bit1	bit0
Ch A >	Ch B >	Ch C >	Ch D >	Ch A <	Ch B <	Ch C <	Ch D <

All registers think in positive logic. A „1“ results in an active state.

Example: P3_P4_P0:<lf>8?8000

Front panel switches: 8? (38 hex and 3F hex) results in 8F hex
=> external Relay on, Auto on and 1mA LED

Measuring Range: 80 (38 hex and 30 hex) results in 80 hex
=> 1 mA Relay active

Automatic ranging: 00 (30 hex and 30 hex) results in 00hex
=> no limit active

5.2.2.16. Querying a rectified channel peak value :MEAS ¹⁾

Command	\$01:MEAS:{CHA CHB CHC CHD ALL}<lf>
Response single value	"{CHA CHB CHC CHD} value"<lf>
Response all values	"ALL valueD,valueC,valueB,valueA,"<lf>
value	is the latest rectified peak value in millivolts in decimal notation

¹⁾ commands available for serial number # 62340 and higher

²⁾ bit 7, 6, 5 only used for serial number # 62340 and higher

³⁾ commands available for firmware version 2.10 and higher

⁴⁾ commands available for firmware version 2.30 and higher

5.3. Upgrading Firmware (download mode)

Following is a procedure on how to manually upgrade a Locum4 device. On request you get the current firmware as a MS Windows executable. Following settings must be thoroughly checked before powering the device.

1) Pins 5 and 10 on connector X1 (auxiliary) should be shorted with a wire. Best to do that is to prepare a male connector with that wire and plug it to X1.

2) Make sure there is a serial connection between the PC and the Locum4 DSub9 marked "RS232"

Power on the device. There is no flicker of range LEDs. Start the program "upgLocum4_Vxxx.exe" followed by the used COM port and the serial number of the device (insert *blank spaces* to separate the parameters each other and from the executable), e.g. "upgLocum4_V230.exe COM1 64123".

The COM port should be the one the LoCuM-4 is connected to. The device serial number is to be found on the back side of every locum4 device at the product label. It's the five digit number after S/N: e.g. "S/N: 64123". Do not use any other number for that device.

You can test the availability of the COM port on a command console by typing in "mode" command or at the device manager. If you try to start upgrade program with no Locum4 connected, program will hang up! Make sure there is a uninterruptible power connection to your Locum4 device! Any power loss while downloading data will corrupt the flash memory and you have to send the device back to the manufacturer liable to pay costs for the repair.

Every firmware is hardware depended. So it can happen that your device is not upgradeable by this upgrade utility. Contact the manufacturer if any problems occur.

Follow the program instructions. If everything is done, switch off the Locum4 device, remove the shorting wire from X1 and power on the Locum4 again.

For latest instructions always check the "readme" file delivered with the upgrade file.

6. Examples for Interfacing

6.1. Using a VME crate to measure monitor signal levels

- VME crate uses a 16-bit ADU board to read four monitor signal levels (+/- 10V)
- To detect the input range of I-U converter you can read the fifth analogue signal (0..+5V)
- Optionally you can use the RS-232 interface (Rx & Tx / 9600 8N1) to read the range and LoCuM-4 status information or command input current range and Bias ON/OFF
- No special software tools will be delivered with LoCuM-4 (mostly the “community” uses EPICS on VME crate to read analogue inputs)
- The connection to the main control system is realized over Ethernet/TCP-IP

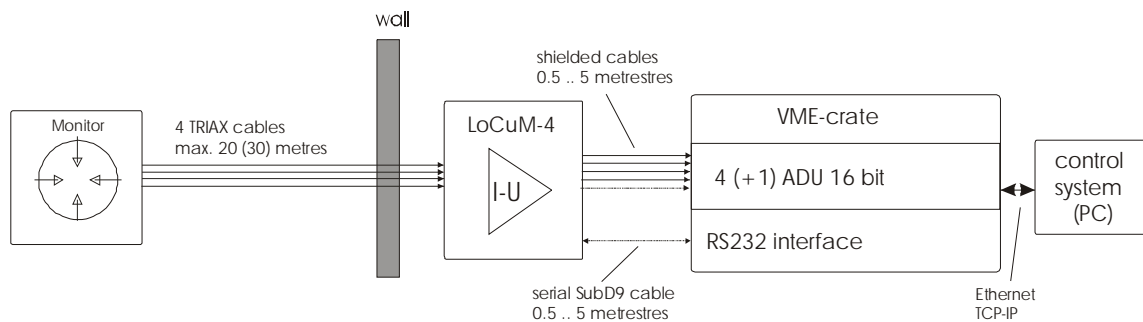

6.2. Using field bus modules to read raw data of position

- Use field bus modules with four 16-bit ADC inputs to read four monitor signal levels (+/-10V)
- To detect the input range of I-U converter you can read a fifth analogue signal (0..+5V)
- Optionally you can read and control the LoCuM-4 via the RS232 field bus modules
- It is possible to use modules with CAN or Ethernet interface to connect to a host system (VME, PC, ...)

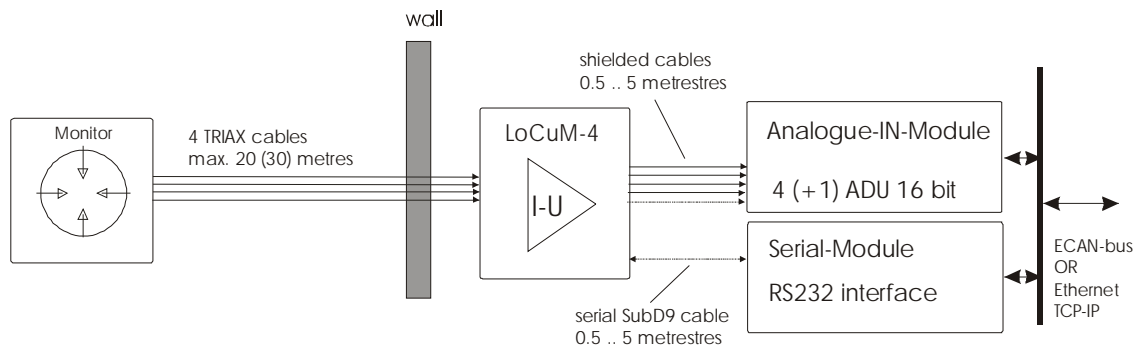

6.3. Using a PC system

- Use a PC-based 16-bit ADU board (i.e. ME-Foxx PCI boards) to read four monitor signal levels (+/-10V)
- To detect the input range of I-U converter you can read the fifth analogue signal (0..+5V)
- Optionally you can read and control the LoCuM-4 via the RS232 interface

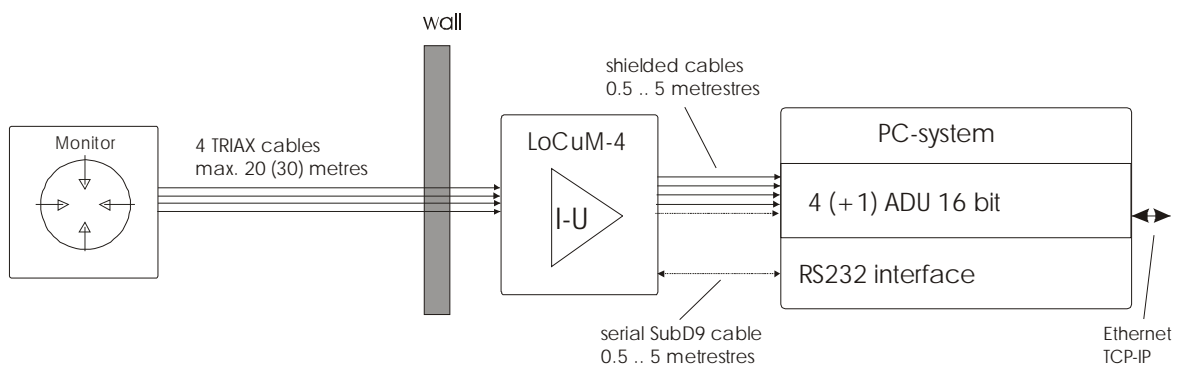

7. Specifications

7.1. General data

Supply voltage	230V AC $\pm 10\%$: 50/60 Hz (option: 115 V AC $\pm 10\%$: 50/60 Hz)
Supply current	inrush peak max. 15A @ 230 VAC < 1ms mean < 250 mA intermittent @ 230 VAC
Size:	19", 2 U, depth: 340 mm
Weight	approx. 7.8 kg
Operating temperature	10...40°C (spec. temperature: 25°C)
Warm-up period:	minimal one hour

7.2. Current Measurement (Ammeter)

Channels:	4
Input currents:	>10pA ... <1 mA; Triax sockets
Input current ranges:	100pA, 1nA, 10nA, 100nA, 1 μ A, 10 μ A, 100 μ A, 1 mA manual or automatic change of measurement range (one selector for all 4 channels)
Accuracy and Frequency response:	see table

Range	Accuracy (DC) of the measuring range (full scale)	Band width: Frequency at the 3 dB – point	Analogue measuring range output
1 mA	0,1 %	≥ 2.4 kHz	4.7V ... 4.9V
100 μ A	0.1 %	≥ 1.7 kHz	4.1V ... 4.5V
10 μ A	0.1 %	≥ 1.9 kHz	3.5V ... 3.9V
1 μ A	0.1 %	≥ 1.4 kHz	2.9V ... 3.3V
100 nA	0.1 %	≥ 360 Hz	2.3V ... 2.7V
10 nA	0.5% + offset 0.1%	≥ 32 Hz	1.7V ... 2.1V
1 nA	0.5% + offset 0.1%	about 1.7 Hz, not specified	1.1V ... 1.5V
100 pA	1.0%	about 0.4 Hz, not specified	0.5V ... 0.9V

The specified accuracies are valid at a temperature of 25°C and with an internal resistance of the following voltmeter of $R_i \geq 100$ kOhm.

Temperature coefficient: 0.1% /K of full scale

Output stability: < 0.1% of full scale

Output signal: -10V...0... +10V (on SUB-D15 connector)

7.3. BIAS Supply

Bias supply is not available with option -B0 and -F2+2

Voltage range:	$\pm 1 \dots 300$ V DC
Stability:	0.5% of full scale
Setting accuracy:	1 % of full scale
Maximum load:	30 kOhm (ohmic) => 10 mA @ 300 V
Bias selection switch	rotary type switch (function control also by RS-232) +BIAS -BIAS 0V (off) External source
Voltage selection:	10-turn-potentiometer
Connection to inputs:	Flip switch (ON/OFF)
Display:	3 ½ -digit LCD display
Monitor output:	SHV socket
External Bias source:	max. 300 V DC max. 100 mA SHV socket
Interlock input:	+5...10 VDC (max. 10mA)

7.4. Pin Assignment

7.4.1. Triax connector (current inputs)

All four current inputs are realized as female Triax BNC jacks (3-lug). You should use a Triax BNC plug (3 lug -180°) for connecting a cable. The Triax inputs of the current-voltage converters are internally wired according to the following drawing.

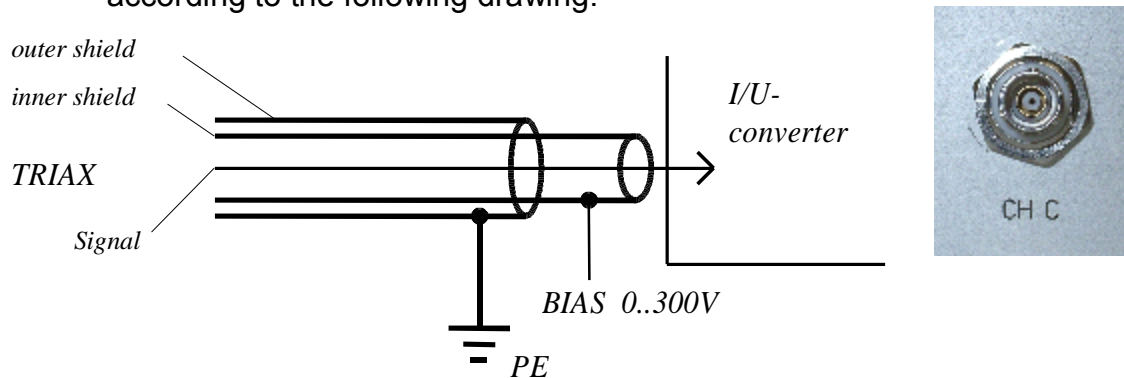

The outer screen of the Triax cable is directly connected with the Chassis (protective ground) over the Triax connector and thus protected against touching high Bias voltages. The inner screen is located on the selected BIAS potential.

When selecting suitable measuring cables, please bear in mind that there might be a potential difference of more than 300V between the inner and outer shield!

7.4.2. SUB-D15 connector (analogue OUT)

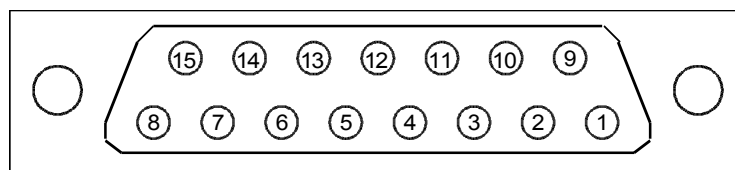

View on the rear panel of the device

PIN	Function	PIN	Function
1	not connected	9	GND
2	Out channel A	10	GND
3	Out channel B	11	GND
4	Out channel C	12	GND
5	Out channel D	13	GND
6	not connected	14	GND
7	Out range	15	GND
8	not connected		

7.4.3. SUB-HD15 connector X1 (Auxiliary)

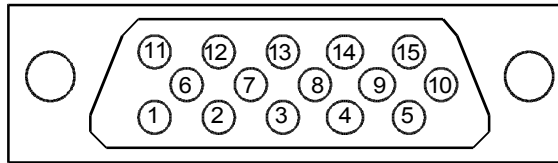

View on the rear panel of the device

PIN	Function	PIN	Function	PIN	Function
1	+ interlock	6	- interlock	11	not connected
2	not connected	7	not connected	12	not connected
3	not connected	8	not connected	13	not connected
4	not connected	9	not connected	14	not connected
5	+ download mode	10	- download mode	15	not connected

Interlock not available with option -B0 and -F2+2 !

7.4.4. SUB-D9 connector (RS-232)

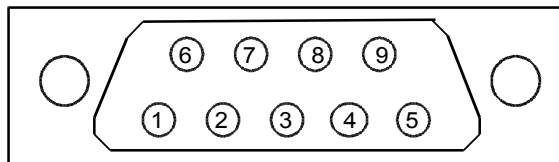

View on the rear panel of the device

PIN	Function	PIN	Function
1	connect. 1-4-6	6	connect. 1-4-6
2	TxD	7	connect. 7-8
3	RxD	8	connect. 7-8
4	connect. 1-4-6	9	not connected
5	GND		

7.4.5. SHV socket (BIAS-OUT)

The outer screen of the SHV socket is directly connected with the housing ground and thus with the protective conductor.

When selecting suitable measuring cables, please bear in mind that there might be a potential difference of more than 300V between the inner and outer shield!

7.4.6. SHV socket (BIAS-IN)

The outer screen of the SHV socket is directly connected with the housing ground and thus with the protective conductor.

The maximum voltage to supply the external Bias input is 300 V DC. This input can be used if your application needs a higher BIAS current than the internal Bias source (max. 10 mA) – up to 100 mA. You can connect sources with positive or negative voltage.

EU-Declaration of conformity

This certificate is issued for the system:

4-Channel Low-Current Monitor

LoCuM-4,

LoCuM-4-B0

manufactured by:

ENZ Ingenieurbüro für
Umwtelektronik & Automatisierung
Friedrich-Wöhler Strasse 2
12489 Berlin
Germany

The system complies with requirements of
European standards as follow:

EN 55011, class B, 2007

EN 61000-6-2, 2005

Declaration issued by
ENZ Ingenieurbüro
Dipl.Ing. Fred Enz
(GM)

Berlin, June 30th, 2009
